

ECO-UNIC

095-CBE (0.995t x 3.5m)

295-CBE (2.90t x 1.4m)

- Total width 0.69m
- Max working radius 8.41m
- Multi-position configurable outriggers (CBE-095)
- Operator control of outrigger extension
- Intelligent voice warning system
- Preliminary stability warning system with motion cut
- Radio remote control as standard
- Working area limitation (CBE-295)
- Optional slew limitation (CBE-295)



Digital battery gauge



Optional searcher hook & fly jib

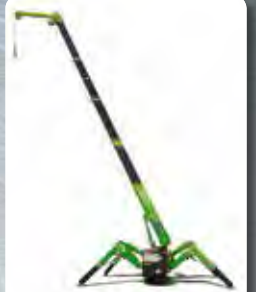

Lifting capacity	700kg (max)
Length	1500mm
Weight	65kg
Tilt angles	0°, 20°, 40°, 60°

This tracked variant of our popular Eco-UNIC cranes retains all the environmentally friendly benefits of our standard wheeled eco models but is able to travel over rough terrain and operate on uneven surfaces. The Eco-UNIC tracked spider crane is the ideal machine for clients looking to reduce their carbon footprint thanks to the on-board rechargeable 48v battery. This mini machine provides fume free lifting, with no harmful emissions impacting on the surrounding atmosphere, making it the perfect option for lifting in sensitive environments, both externally and internally.



CRANE SPECIFICATIONS

Crane capacity	Eco-095: 0.995t x 3.5m Eco-295: 2.9t x 1.4m
Max working radius	max: 8.41m
Max lifting height	max: 8.9m
Rope length	max: 14.12m (4 fall), 29.24m (2 fall), 59.47m (1 fall)
Dimensions	folded: 2720mm (l) x 690mm (w) x 1525mm (h)
Weight	unladen: 2350kg (2415kg with fly jib)
Point loadings	Due to the many variables involved, point loadings are only available on request
Hook speed	approx: 91m/min (with 4 layers and 4 falls)
Telescopic system	boom length: 2.53 - 8.65m telescoping speed: 612m/31 seconds boom type: 5 section, hydraulically telescoping boom, hexagonal box construction
Derricking angle/speed	approx: 0 - 78° / 17 Seconds
Slewing angle/speed	approx: 360° (continuous) 1.5 rpm
Travelling system	drive: hydrostatic, stepless forward and reverse travel speed: 0 - 1.4 km/h gradeability: 20° (vertical), 10° (traverse) track ground length: 1050mm track ground pressure: 48kPa (0.49 kg/cm ²) track width: 180 mm
Power source	power: 4.0kW (AC motor) voltage: 48v DC rechargeable battery
Battery charger	charger: 200/240v single phase (15A)
Standard equipment Eco-095	radio remote control, overwinding alarm, computer controlled intelligent voice warning system, multi-function operation by radio remote control, intelligent throttle activation, automatic hook stow, load indication, turn-over protection system with stability warning lamps and alarm
Standard equipment Eco-295	computer controlled moment limiter (safe load indicator), radio remote control, overwinding alarm, computer controlled intelligent voice warning system, multi-function operation by radio remote control, intelligent throttle activation, automatic hook stow, overload warning alarms, overload warning lamps, working area limitation, ground contact warning light
Optional equipment	1 fall hook block, 2 fall hook block, 300kg capacity small searcher hook, 700kg capacity searcher hook, 700kg capacity fly jib with single part line

ADDITIONAL FEATURES



Radio remote control



Full safe load indicator

MINI SPIDER CRANE

BATTERY CRANE ON CRAWLERS



RATED LOADS & OUTRIGGER POSITIONS

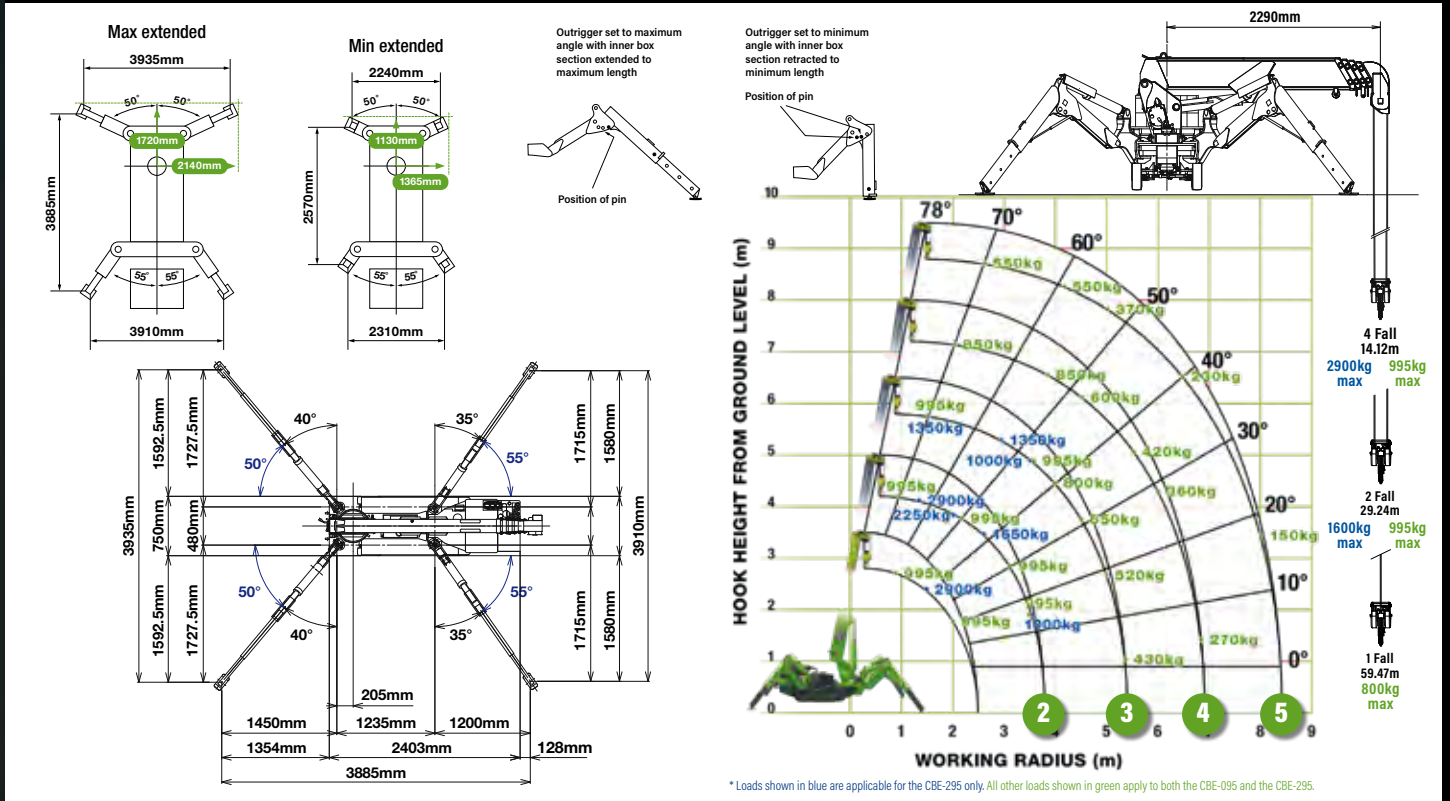

SECOND STAGE EXTENDED 2.53 - 4.075M BOOM LENGTH

Working radius	m	up to 1.0	1.4	1.5	1.8	2.0	2.5	3.0	3.5	3.835	
Outrigger	Max-extended	kg	995 (2,900)	995 (2,900)	995 (2,650)	995 (2,250)	995 (2,050)	995 (1,650)	995 (1,300)	995 (1,000)	900
	Min-extended	kg	995 (2,000)	995 (2,000)	995 (2,000)	995 (1,450)	995 (1,100)	650	490	350	250

* Loads shown in blue are applicable for the CBE-295 only. All other loads shown in black apply to both the CBE-095 and the CBE-295.

THIRD STAGE EXTENDED 4.075 - 5.61M BOOM LENGTH

Working radius	m	up to 2.2	2.5	2.9	3.0	3.5	4.0	4.5	5.0	5.37	
Outrigger	Max-extended	kg	995 (1,350)	995 (1,350)	995 (1,350)	995 (1,250)	995 (1,000)	800	650	520	430
	Min-extended	kg	800	650	530	500	380	280	220	160	120

FOURTH STAGE EXTENDED 5.61 - 7.13M BOOM LENGTH

Working radius	m	up to 3.4	3.8	4.0	4.5	5.0	5.5	6.0	6.5	6.89	
Outrigger	Max-extended	kg	850	850	750	600	500	420	360	320	270
	Min-extended	kg	420	340	300	250	190	140	100	80	60

FIFTH STAGE EXTENDED 7.13 - 8.65M BOOM LENGTH

Working radius	m	up to 3.8	4.1	4.5	5.0	5.5	6.0	6.5	7.0	8.0	8.41	
Outrigger	Max-extended	kg	550	550	450	370	310	270	230	200	150	130
	Min-extended	kg	350	290	250	200	160	130	100	70	40	30

SEARCHER HOOK SMALL - 300KG

Stowed position



In operation



Lifting capacity 300kg (max)

Length 500mm

Weight 15kg

Tilt angles 0°, 20°, 40°, 60°

DIMENSIONS

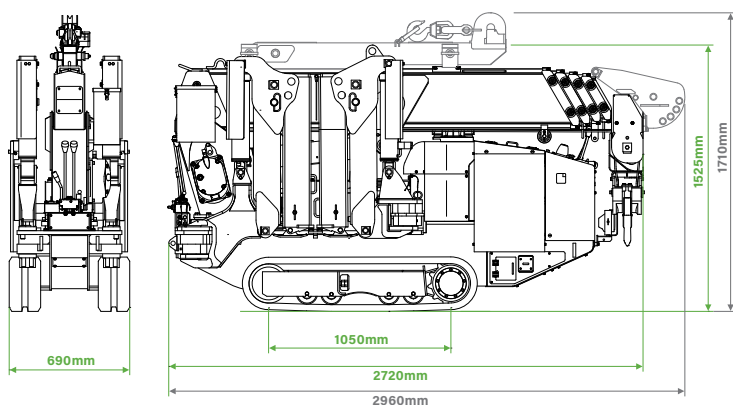

OUTRIGGER POSITIONS

